

Installation Note

Agilent Technologies E4404B/05B Spectrum Analyzers and E7403A/04A EMC Analyzers Low Frequency Extension (Option UKB) Retrofit Kit



Agilent Technologies

Part Number E4404-90006 Supersedes: E4404-90005, E7404-90002
Printed in USA August 2003



E4404- 90006

Notice.

The information contained in this document is subject to change without notice.

Agilent Technologies makes no warranty of any kind with regard to this material, including but not limited to, the implied warranties of merchantability and fitness for a particular purpose. Agilent Technologies shall not be liable for errors contained herein or for incidental or consequential damages in connection with the furnishing, performance, or use of this material.

Introduction

This procedure can be used to retrofit a 100 Hz Low Frequency Extension (Option UKB) into your analyzer. This kit contains nameplates and connector labels for all models listed. Only one nameplate and one connector label will be used for each model.

Products Affected:	E4404B, E4405B E7403A, E7404A
Serial Numbers:	US00000000/US99999999 MY00000000/MY99999999
Options:	UKB
To Be Performed By:	(X) Agilent Technologies Service Center (X) Personnel Qualified by Agilent () Customer
Estimated Installation Time:	3.0 Hours
Estimated Verification Time:	2.0 Hours

Installation Kit Parts Lists

Quantity	Description	Part Number
1	Cable Assembly, Filtered Low Band RF Input (W35)	E4404-20026
1	Connector Label, E4404B/E7403A Option UKB	E4404-80007
1	Connector Label, E4405B/E7404A Option UKB	E4405-80005
1	Nameplate, E4404B Option UKB	E4404-80008 ^a
1	Nameplate, E4405B Option UKB	E4405-80006 ^a
1	Nameplate, E7403A Option UKB	E7403-80002 ^b
1	Nameplate, E7404A Option UKB	E7404-80002 ^b
1	Option UKB Retrofit Installation Note	this note
1	Option Upgrade Entitlement Certificate	---

- a. ESA unique material
- b. EMC unique material

Tools Required

- T-10 TORX screwdriver
- T-15 TORX screwdriver
- Flat-blade screwdriver
- Sharp knife or razor blade
- Function Generator
- Synthesized Sweeper
- Digital Voltmeter
- Power Meter, Dual-Channel
- RF Power Sensor (2 required)
- Microwave Power Sensor
- 50 Ω Termination
- Power Splitter
- 20 dB Attenuator
- APC 3.5 (m) Cable Assembly
- APC 3.5 (m) to Type N (m) Adapter
- APC 3.5 (m) to Type N (f) Adapter
- BNC Tee (f,m,f)
- Dual Banana to BNC (f) Adapter
- Adjustment Software

The Performance Verification and Adjustment Software may be obtained by ordering the Service documentation and Software (Option 0BW).

Torque Settings

To avoid potential RFI leakage and prevent connector damage, tighten to the following torque limits:

Item	Torque	
	In-lb	N-cm
SMA Connectors	8.5	95
3-mm, T-10 TORX screws	9	102
4-mm, T-15 TORX screws	21	236

Procedure

Verify A8A1 3 GHz RF Assembly Part Number

1. Turn on the analyzer and wait for the initial adjustments to complete.
2. Press **System, More, Show Hdwr**. This displays the Show Hardware screen, which lists the part number and serial number of most of the installed board assemblies.
3. Locate the part number of the “50Ω 3 GHz Input” assembly.
4. If the part number of the 50Ω 3 GHz Input assembly is E4403-60033 or lower, the A8A1 3 GHz RF assembly must be replaced. If the analyzer does not have the High Stability Frequency Reference, Option 1D5, order E4403-60073. If the analyzer does have Option 1D5, order E4403-60074.

WARNING Before you disassemble the instrument, turn the power switch OFF and unplug the instrument. Failure to unplug the instrument can result in personal injury.

CAUTION Electrostatic discharge (ESD) can damage or destroy electronic components. All work on electronic assemblies should be performed at a static-safe workstation. Refer to the documentation that pertains to your instrument for information about static-safe workstations and ordering static-safe accessories.

Dress Cover Removal

1. Referring to Figure 1, disconnect the analyzer from ac power (1).
2. Remove any adapters or cables (2) connected to the front frame.
3. Carefully place the analyzer on the work surface with the front frame (3) facing down.
4. Position the handle (4) as shown.
5. Remove the four screws (5) that hold the rear frame and dress cover in place.
6. Remove the rear frame (6).
7. Pull the dress cover (7) off towards the rear of the analyzer.

Figure 1 Dress Cover and Rear Frame Removal

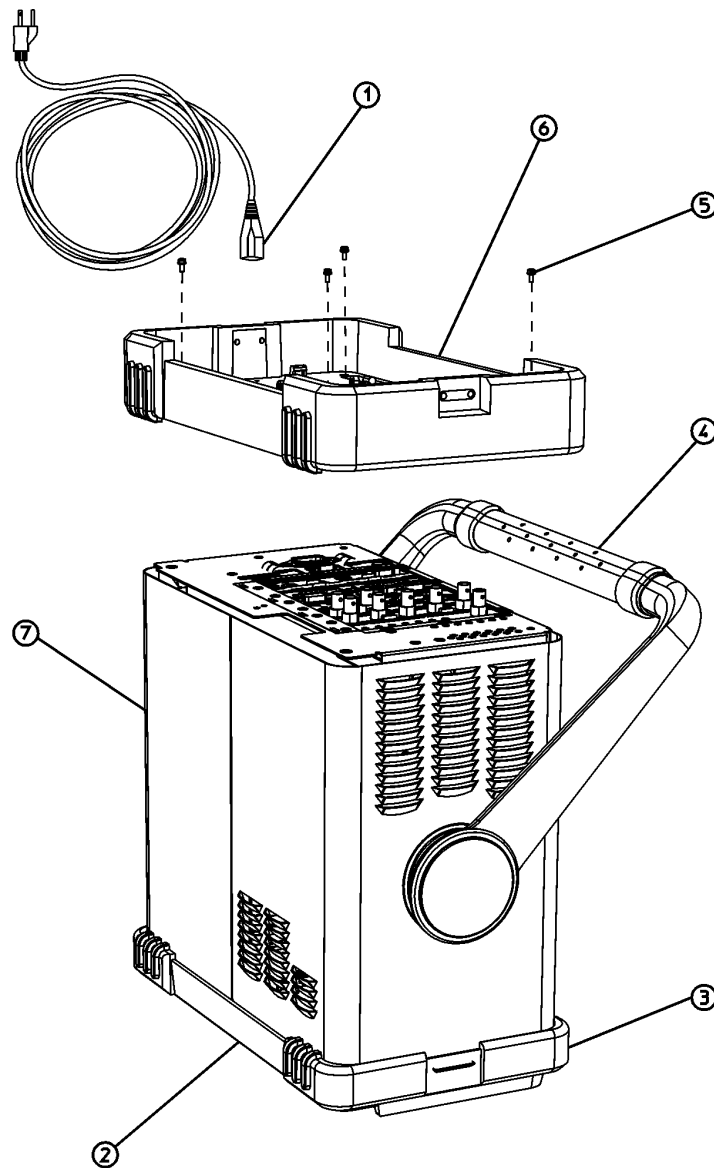

dl71b

Chassis Cover Removal

1. Lay the analyzer flat as shown in Figure 2.
2. Remove the 15 screws (2) and (3) attaching the chassis cover to the chassis. Note that the number of screws attaching the chassis cover may vary with option mixes.
3. Remove the chassis cover (1) from the chassis.

Figure 2 Chassis Cover Removal

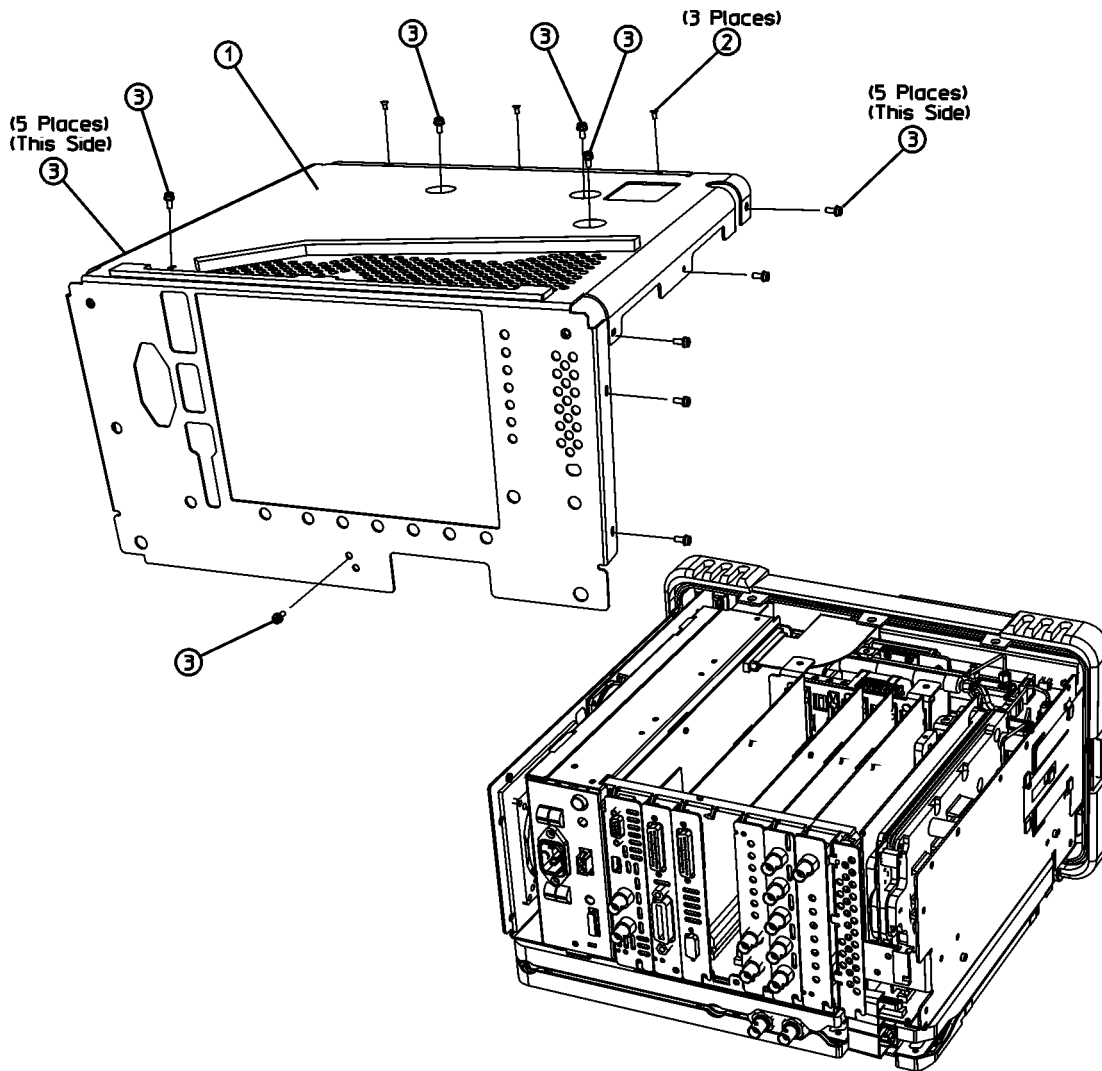

dl72b

A1 Front Frame Assembly

CAUTION Use ESD precautions when performing this replacement procedure.

1. Refer to Figure 3. Remove the two screws (1), on the bottom side of the instrument, that secure the front frame to the RF assembly.

Figure 3 A1 Front Frame Assembly Removal

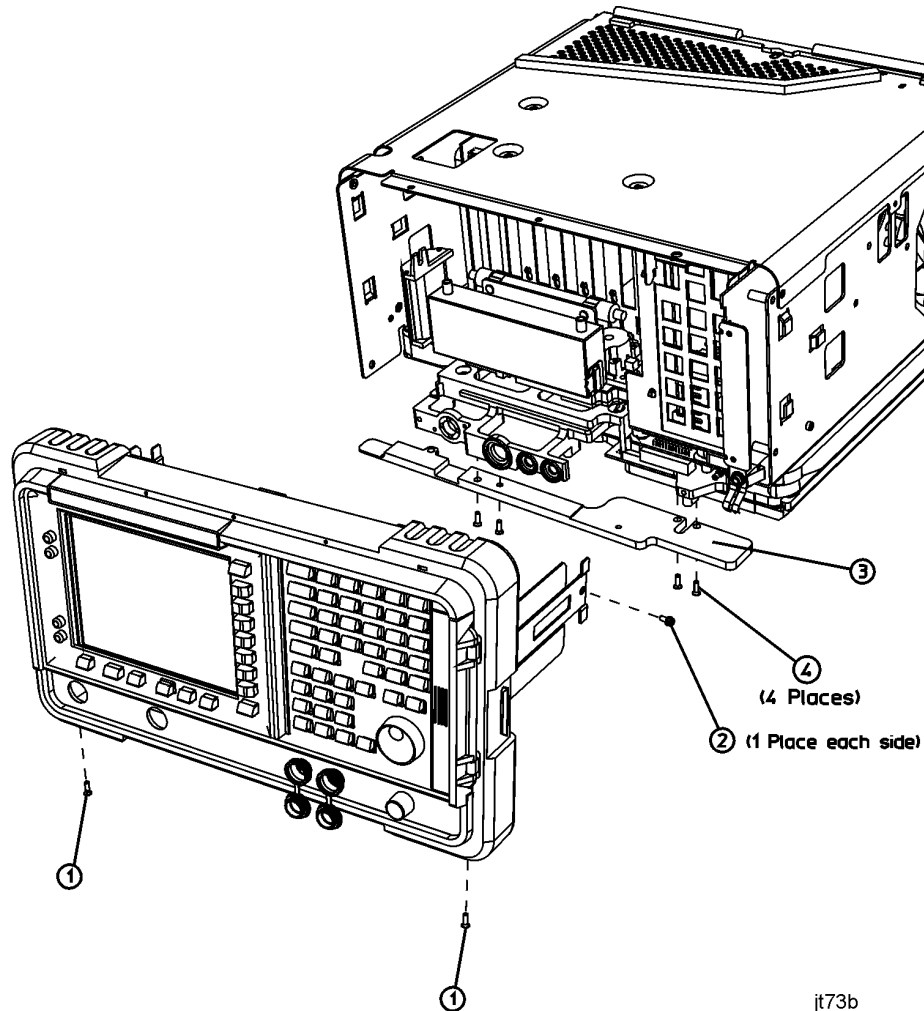

2. Place the instrument with the top side facing up and remove the remaining two screws (2) that secure the front frame subpanel to the chassis.
3. Slide the front frame forward until it catches on the tabs on the sides of the chassis.

4. Refer to Figure 4. Disconnect the ribbon cable (1) from the A1A1 front panel interface board.

NOTE Analyzers with Option B7B will have a second ribbon cable connecting to A1A1. Disconnect the second ribbon cable if present.

Figure 4 **Front Frame Ribbon Cable**

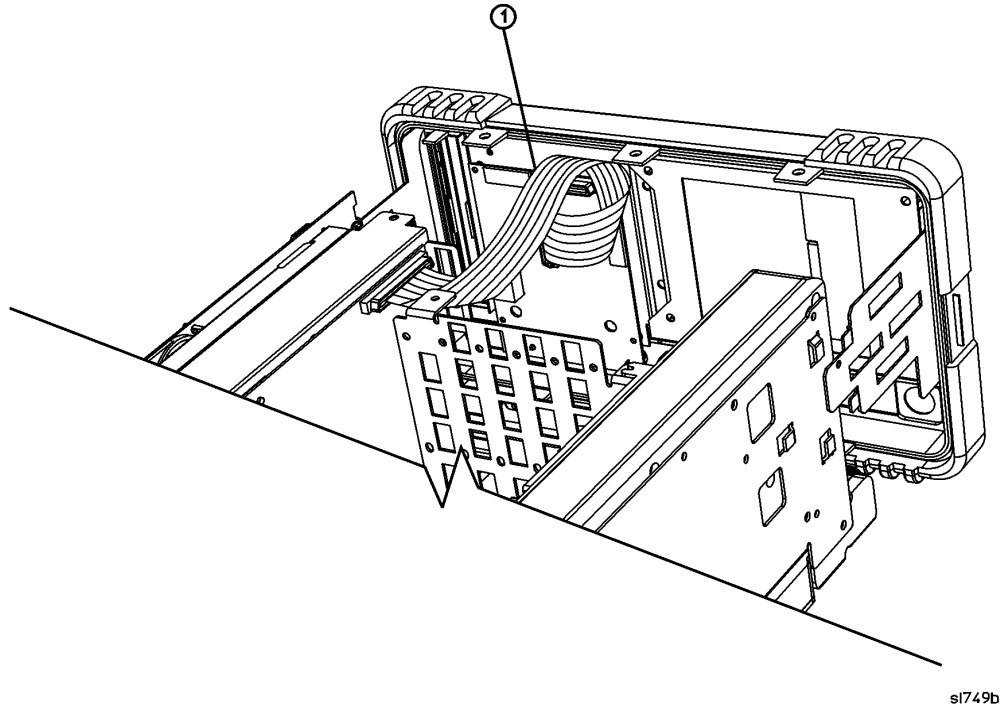

5. Carefully pull the sides of the front frame subpanel away from the chassis and over the tabs on the chassis.
6. Slide the front frame forward to disengage from the chassis assembly.

A1A1 Front Panel Interface Board Removal

1. Refer to Figure 5. Remove the disk drive door (1).
2. Remove the RPG knob (2).
3. Remove the volume knob (3).

TIP You may need to exert considerable force in order to remove the RPG knob. It may be necessary to pry it off using a screwdriver as shown in Figure 5.

Figure 5 Removing the Front Frame Knobs

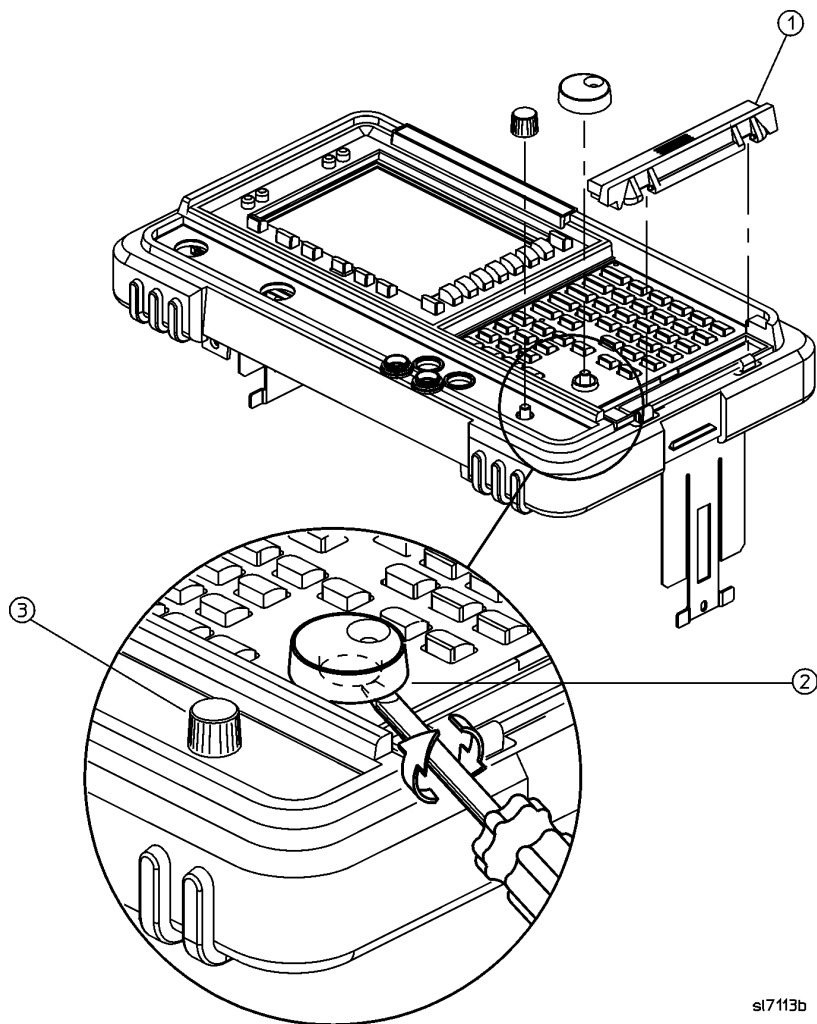

4. Refer to Figure 6. Disconnect the two 2-wire backlight cables (1) from the front panel interface inverter board.
5. Disconnect W3 ribbon cable (2) from the front panel interface board.

Figure 6 **Disconnecting the Front Frame Wiring Connections**

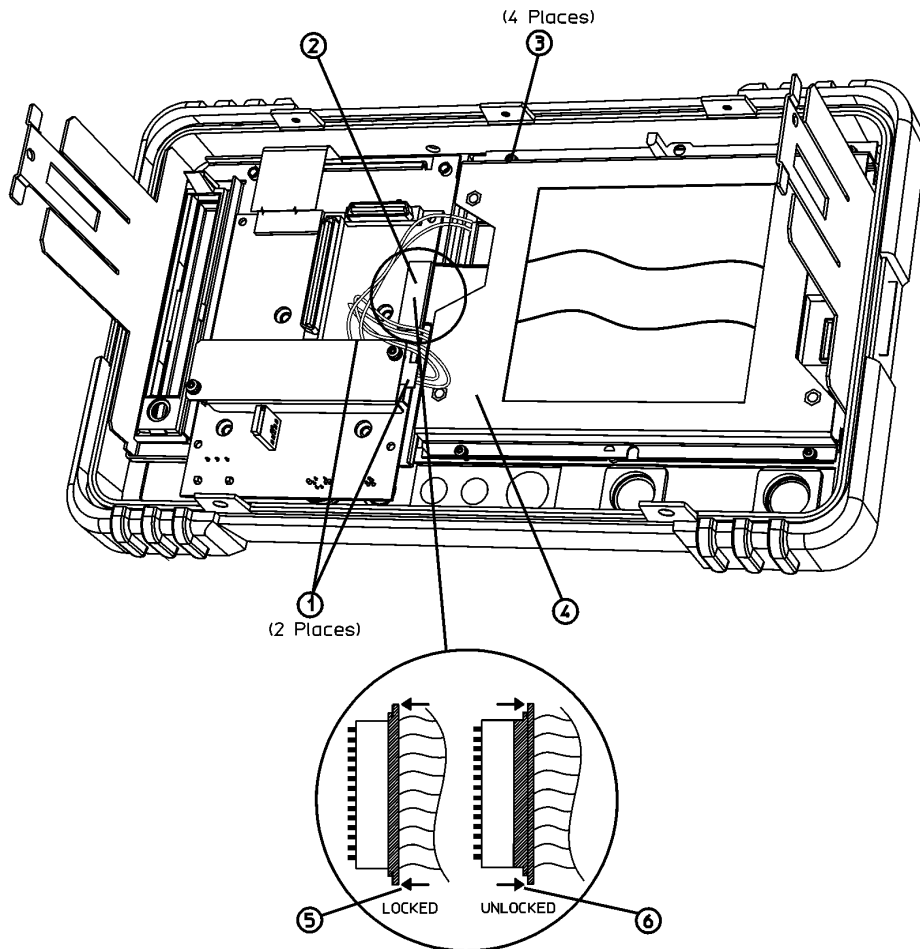

sl748b

CAUTION The W3 display ribbon cable connector (2) is delicate. With a small screwdriver or similar tool, gently push the lock tabs out from the back of the connector. Excessive force on the locking tab can break the retaining clips, and if broken, board replacement will be necessary.

6. Refer to Figure 7. Remove the four screws (10) that secure the A1A1 front panel interface board (11) to the front frame.
7. Remove the front panel interface board from the front frame assembly.

Removal

NOTE There is a water-seal gasket placed around the volume control shaft that will need to be repositioned during the replacement procedure.

Figure 7 Front Frame Assembly Parts

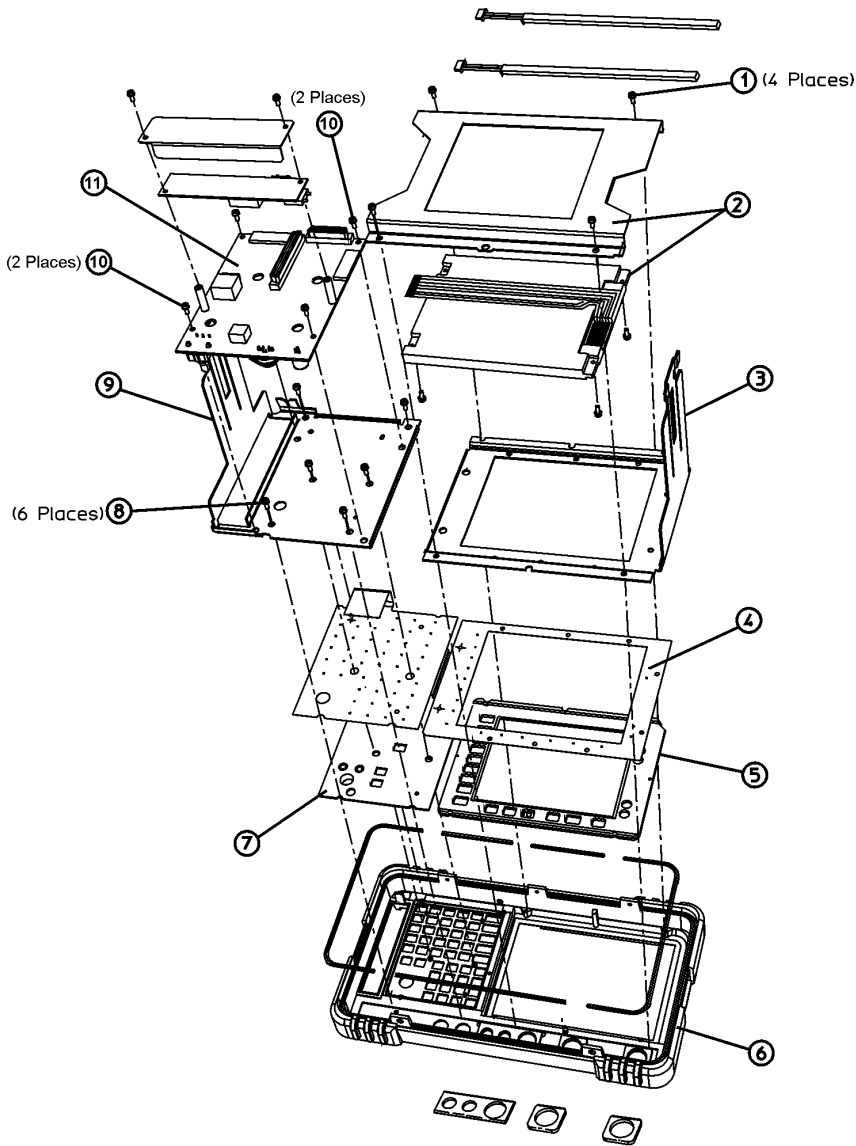

jl73a

Attach Nameplate to Front Frame

1. Locate the correct nameplate in the kit. The nameplate is labelled with the analyzer product number and the analyzer's frequency range. This kit contains multiple nameplates, use the nameplate for your model.
2. Remove the existing nameplate (1) as shown in Figure 8.
3. Clean the surface (2) of any adhesive residue.
4. Peel the backing (3) off the new nameplate and place it (4) as shown.

Figure 8 **Nameplate Replacement**

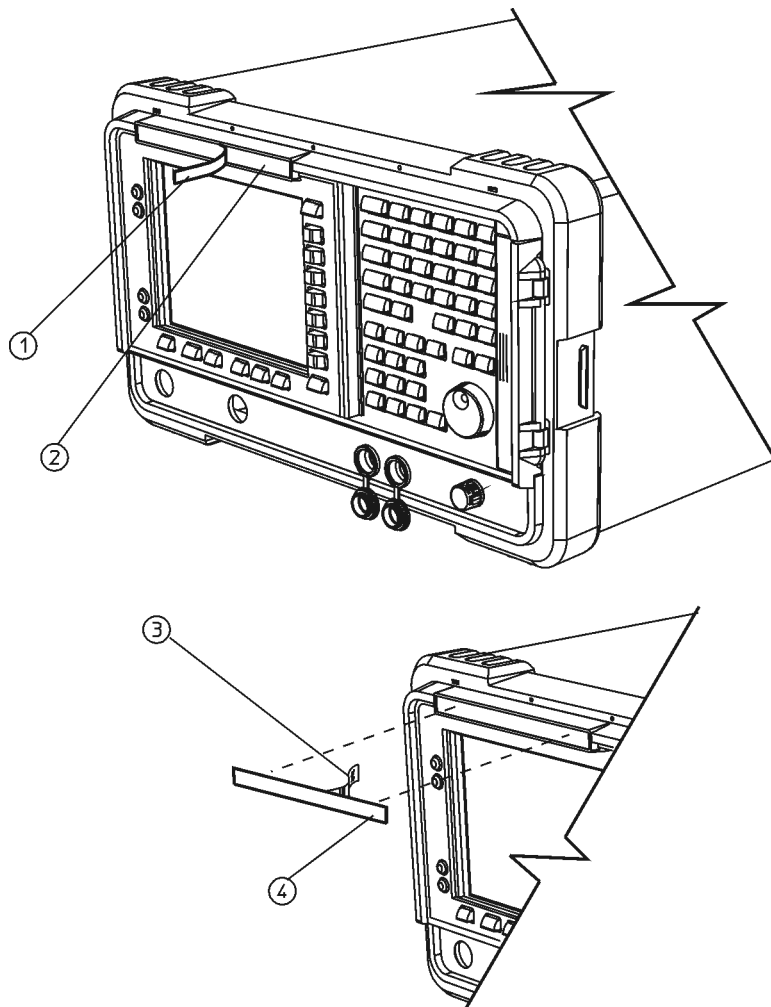

sl7114b

Attach Connector Label and Connector Covers to Front Frame

1. Locate the appropriate connector label in the kit. The connector label has holes to accommodate the various front panel connectors and the volume control. The frequency range of the analyzer appears near the hole next to the INPUT connector. This kit contains two connector labels identifying different frequency ranges for different analyzers. Choose the connector label that is appropriate for the analyzer being retrofitted.
2. Refer to Figure 9. If the analyzer does not have a tracking generator, remove the hole plug for the RF OUT connector.
3. Remove the two connector covers from the front panel by pinching them from the sides and removing them (4) through the front of the front frame assembly.

Figure 9 Connector Covers

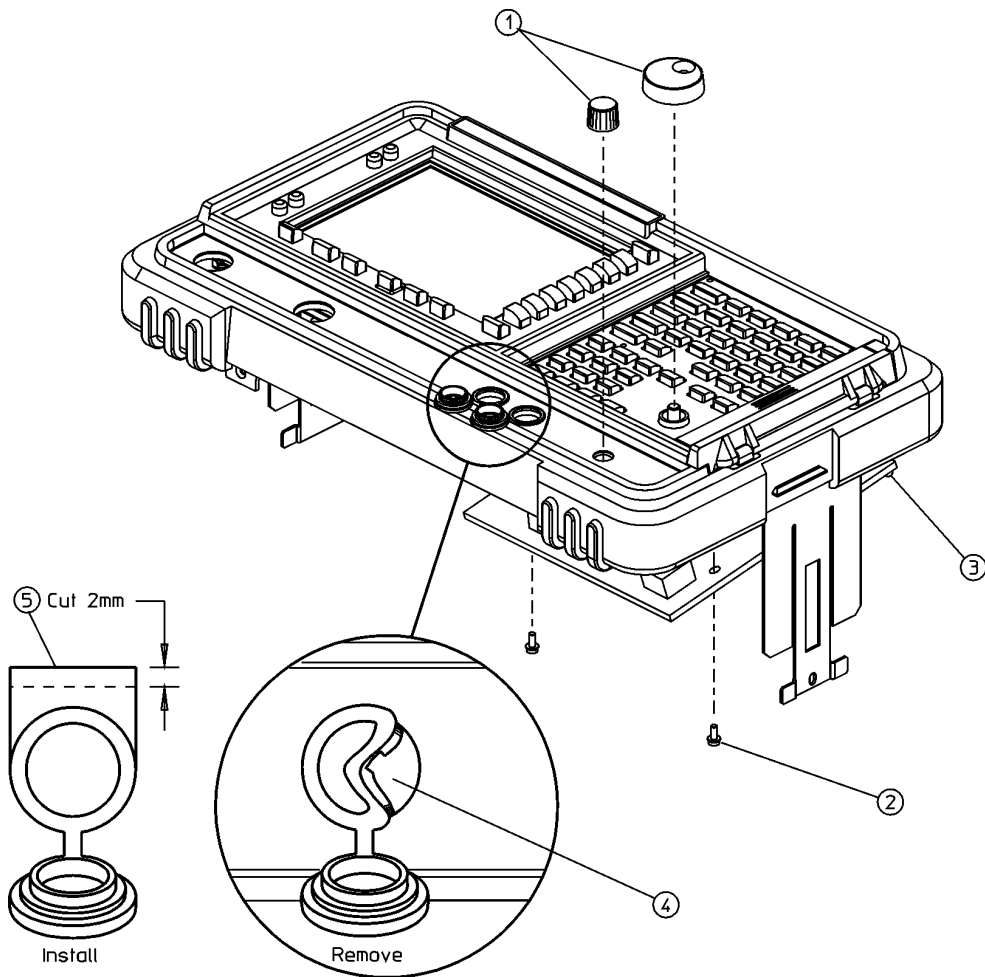

sl711b

Figure 10 Connector Label Installation

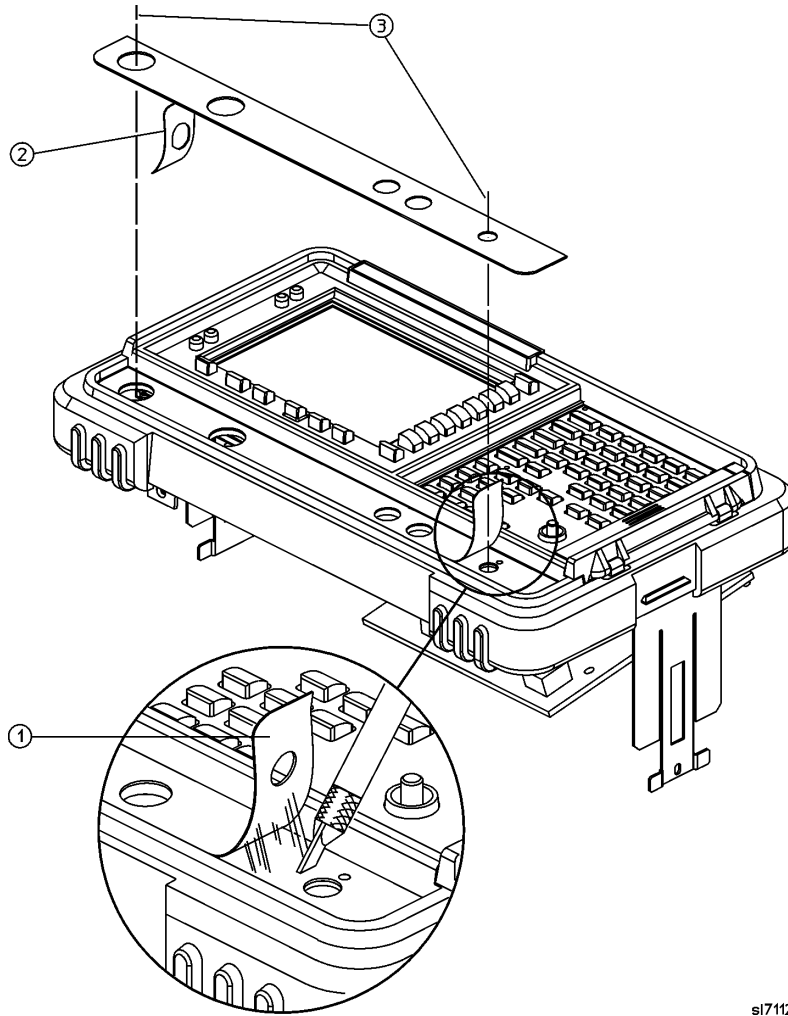

sl7112b

4. Peel off the old connector label loosening any residual adhesive with a sharp knife or razor blade as you go.
5. Before installing the new connector label, make sure the surface is free of any adhesive residue left from the old label. Failure to do so may result in an uneven (lumpy) appearance of the new label.
6. Peel the backing (2) off the new label, as shown in Figure 10.
7. Align and install the label by placing a finger in the RF OUT and VOLUME holes (3). Observe the alignment of the INPUT and PROBE POWER holes.

TIP Refer to Figure 9. It may be helpful to trim off about 2 mm of the tabs (5) on the connector covers prior to reinstalling them. This will help in aligning the covers.

8. Reinstall the two connector covers from the front panel by pinching them from the sides and installing them through the front of the assembly.
9. Align the connector covers so they open downward.
10. Reinstall the hole plug that was removed if your analyzer does not have a tracking generator.

Figure 11

Microwave RF Assembly Front View, Semi-rigid Cables E7403A and E7404A

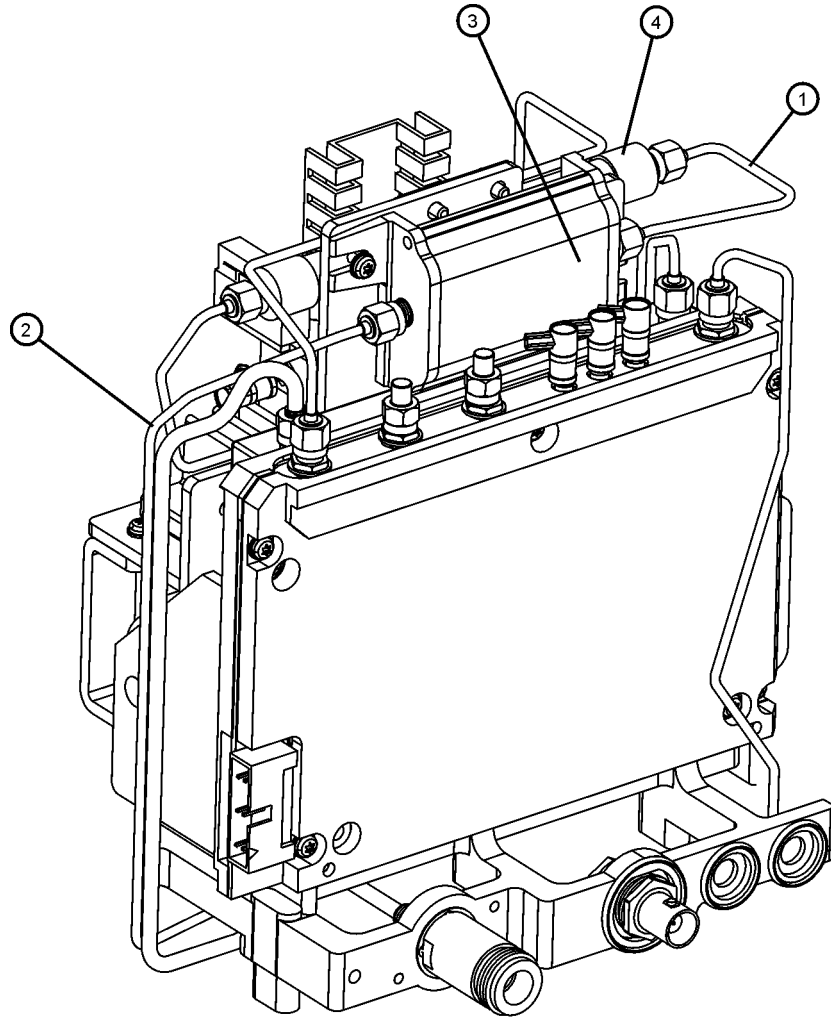

jt71b

1. Refer to Figure 11. Locate W19 (1). W19 is a semi-rigid coax cable connected between the A8A3 DC block (3) and A8FL1, the 3 GHz Low Pass Filter (4). Remove W19 (1).
2. Disconnect W8 (2) from the A8A3 DC block (3).
3. Rotate the analyzer so that the right side is resting on the table.
4. Disconnect W8 from A8A1A2J2.
5. Remove the A8A3 DC block (3).

Figure 12 **Connect Semi-Rigid Cables to Microwave RF Assembly**

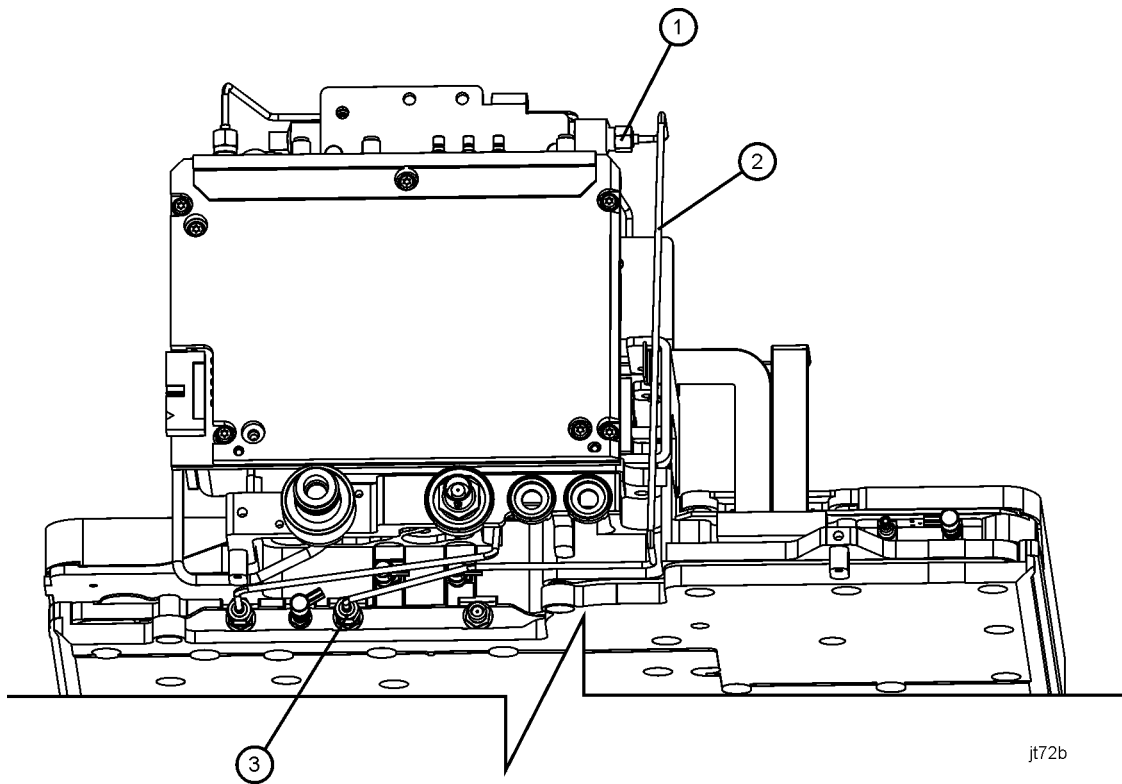

jt72b

6. Refer to Figure 12. Connect the new W35 coax cable (2) supplied in this kit between the output of A8FL1 (1) and A8A1A2J2 (3). Torque the connections to 10 in-lbs.

Replace A1A1 Front Panel Interface Board

1. Refer to Figure 13. Place the front panel interface board (11) in the correct position in the front frame assembly. Make sure the water seal is in place around the volume control shaft.
2. Replace the four screws that secure the board to the front frame. Tighten them to 9 inch-pounds.

Figure 13 Front Frame Assembly Parts

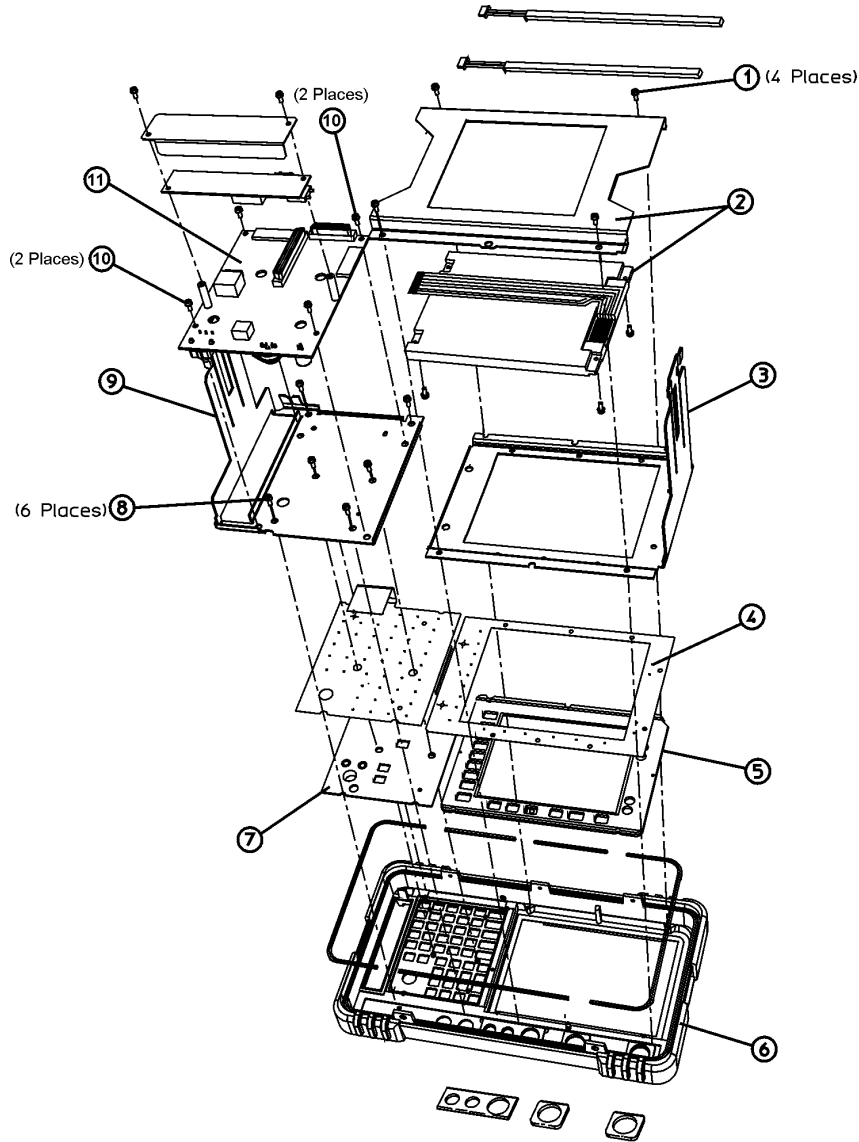

jl73a

3. Refer to Figure 14. Connect the W3 display ribbon cable (2) to the front panel interface board.

TIP

An easy way to insert this delicate cable into the connector is to place your finger on the cable, in the center of the LCD display, and gently slide the cable toward the connector until they align. Then, providing guidance with the other hand as necessary, slide the cable until the end slips into the connector.

Ensure the cable end is seated completely and is aligned straight within the connector body.

Continue to hold the cable in place with your finger, and with the other hand gently press the locking tabs (5) into place.

If you experience display problems, check this connection.

4. Reconnect the two 2-wire backlight cables (1) to the inverter board, making sure that the cables are dressed away from the openings for the control knobs.

Figure 14 Connecting the Front Frame Wiring Connections

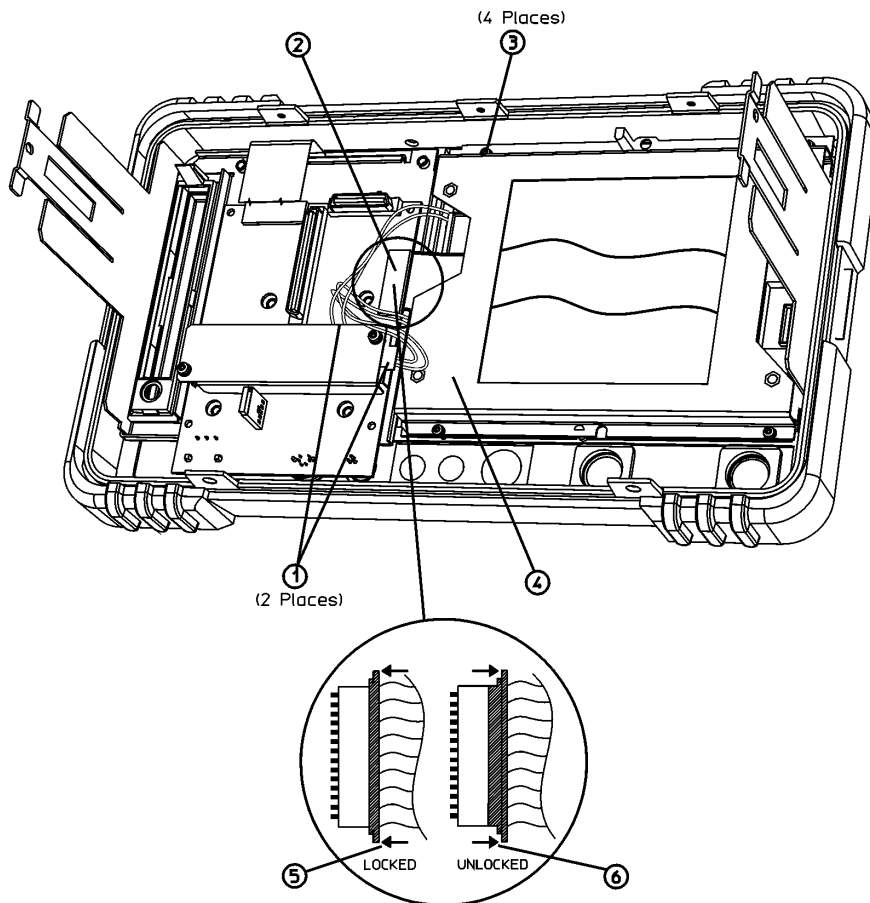

si748b

5. Press the volume and RPG knobs onto their control shafts.

Replace Front Frame Assembly

1. Align the A1 front frame subpanel rails with the chassis as shown in Figure 15.

Figure 15 Front Frame Assembly Replacement

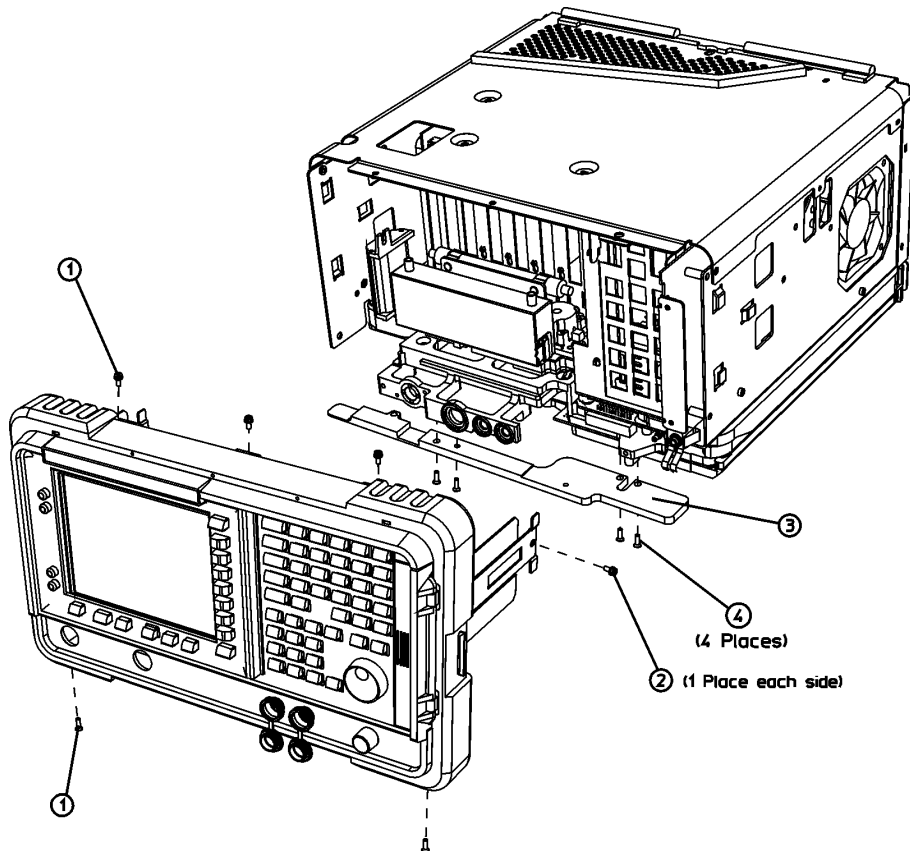

sl71f8b

2. Refer to Figure 16. Connect the ribbon cable (1) to the front frame assembly.

NOTE If Option B7B is installed, there will be two ribbon cables to connect. Be sure to use the outermost connectors on the B7B ribbon cable, as the inner connectors are grounds only. These grounds were designed to suppress EMI.

Figure 16 Front Frame Ribbon Cable

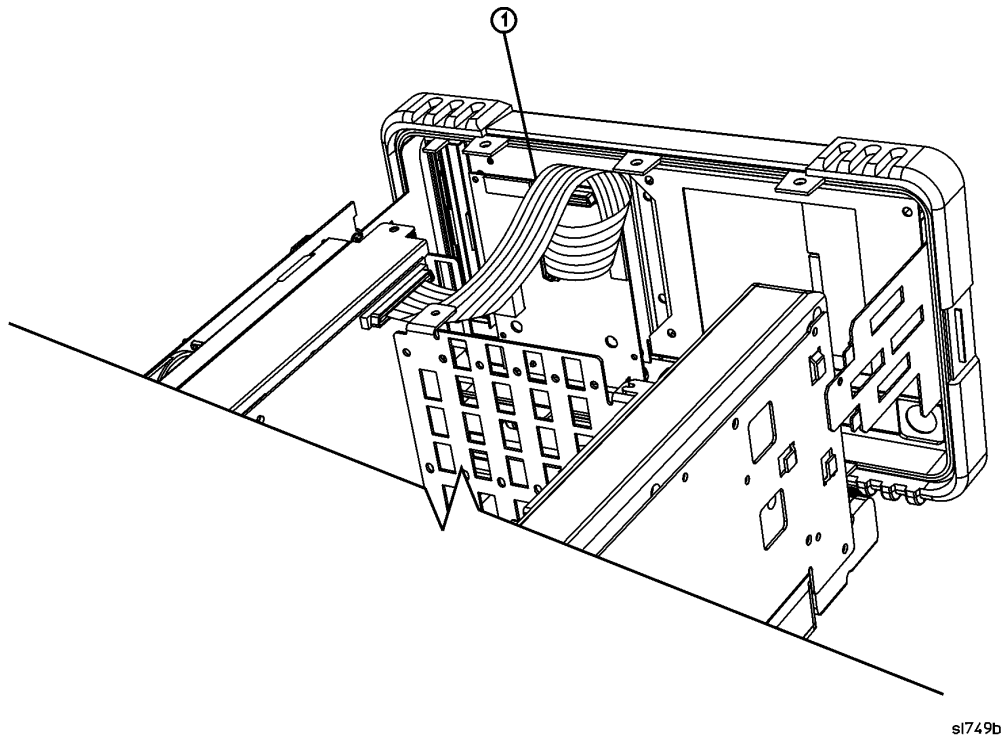

3. Carefully slide the front frame toward the chassis, assuring the ribbon cable(s) are not pinched between assemblies, and the RF input connector lines up correctly with the opening in the front frame.
4. Refer to Figure 15. Replace the screws that secure the front frame to the chassis (2) and to the RF assembly (1). Tighten them to 9 inch-pounds.

Replace Chassis Cover

Figure 17 Chassis Cover Replacement

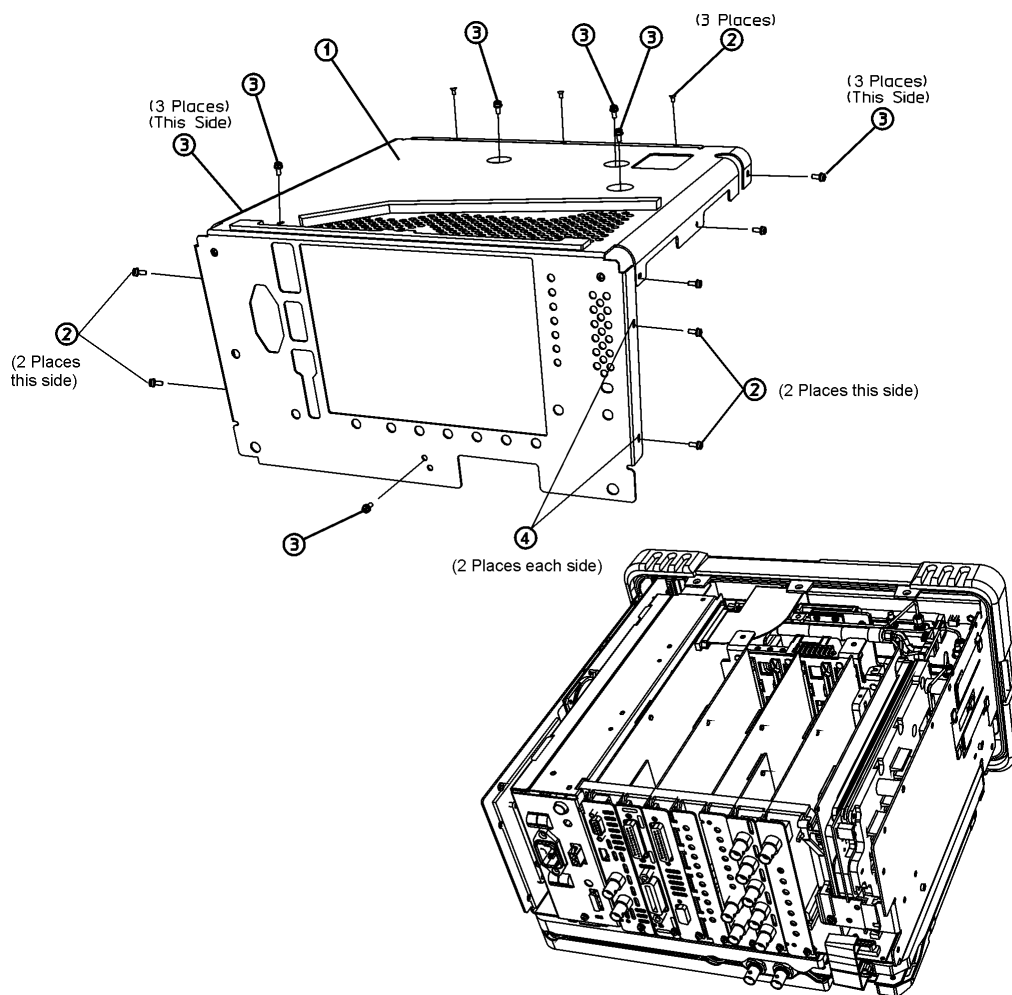

j174a

1. Carefully position the chassis cover (1) on the instrument as shown in Figure 17, then lower onto the instrument.
2. Replace the 17 screws (2) and (3) as indicated on the instructions on the chassis cover. Tighten the screws to 9 inch-pounds.

Replace Dress Cover

1. Refer to Figure 18. Carefully place the analyzer on the work surface with the front frame (3) facing down.
2. Replace the dress cover, matching the grill (8) on the bottom of the dress cover to the bottom of the analyzer.
3. Fit the leading edge of the dress cover completely into the slot (9) on the back of the front frame assembly.
4. Replace the rear frame assembly (6) using the four screws (5) to fasten the rear frame to the analyzer. Tighten them to 21 inch-pounds.

Figure 18 Dress Cover, Rear Frame Replacement

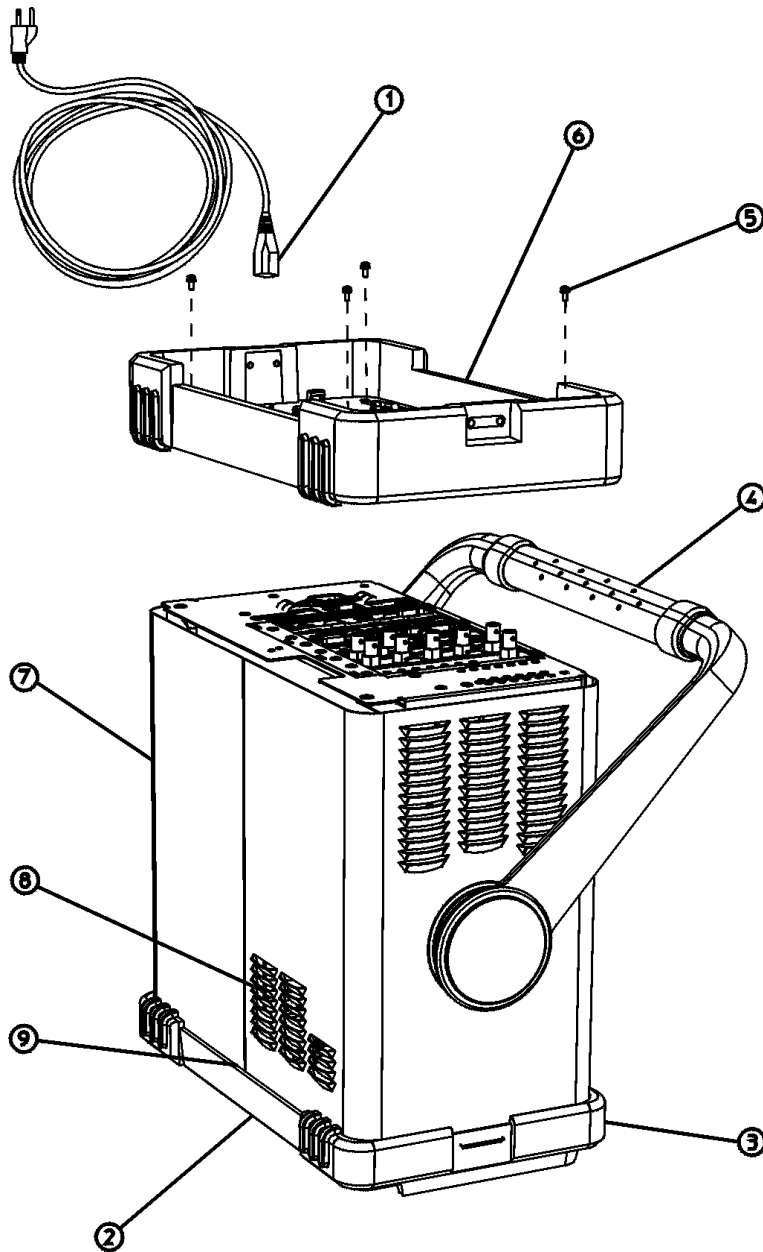

sl745b

Firmware Revision Verification

1. Turn on the analyzer and wait for the power-on alignments to complete. Check that there are no error messages displayed.
2. Press **System, More, Show System**. Make a note of the firmware revision.
3. If the firmware revision is A.05.00 or later, the firmware does not need to be upgraded and you can skip step 4 through 6. However, if the instrument being upgraded has Option B72, Expansion Memory, Agilent recommends you upgrade the instrument firmware to the current version. See steps 5 and 6.
4. If your firmware revision is prior to A.05.00, you must upgrade your analyzer firmware to be compatible with upgrade Option UKB.
5. For models E7403A and E7404A, use one of the following methods:
 - Download the instrument firmware via the world-wide web at http://www.agilent.com/find/emc_firmware. This entire process of upgrading firmware will take approximately 45 minutes.
 - Receive the latest firmware upgrade disk set by ordering upgrade Option UE2.
Note: Special instructions in the Agilent ordering configurator should have made you aware of Option UE2 in case access to the internet wasn't available.
6. For models E4404B and E4405B, press **System, More, Show System** and see if Option B72, Expansion Memory, is listed on the display.

If Option B72 is installed you should upgrade the instrument firmware using one of the following methods:

- Download the instrument firmware via the world-wide web at http://www.agilent.com/find/esa_firmware. This entire process of upgrading firmware will take approximately 45 minutes.
- Receive the latest firmware upgrade disk set by ordering upgrade Option UE2.
Note: Special instructions in the Agilent ordering configurator should have made you aware of Option UE2 in case access to the internet wasn't available.

If Option B72 is not installed, you should upgrade the instrument firmware using one of the following methods:

- Download the instrument firmware via the world-wide web at http://www.agilent.com/find/esa_firmware_std-mem. This entire process of upgrading firmware will take approximately 45 minutes.
- Order upgrade Option B72, which includes the expansion memory and the latest ESA firmware upgrade disk set.

Obtaining a License Key and Activating the Option

The entitlement certificate supplied in this kit allows you to obtain a license key from our Agilent website so you can enable this upgrade option. Once you have retrieved the license key, you can begin the process of activating the option.

1. Press **System, More, More, Licensing, Option**. When you press **Option**, the alpha editor will be activated. For instructions on using the alpha editor, refer to the analyzer User's Guide.
2. Use the alpha editor to enter the three-character designation for the option, in this case, "UKB", that you want to activate.
3. Press **Enter** when done.
4. Press **License Key**. When you press **License Key** the alpha editor will be activated.
5. Use the alpha editor and the numeric keypad to enter the 12-character license key number (for example: D7C374DABD5B) for the option that you want to activate.
6. Press **Enter** when done.
7. Press **Activate** to turn on the option.
8. If the option and license key entries were correct, a message stating "Option Activated" will appear on the analyzer display.

Adjustments and Performance Verification

1. Verify that Option UKB was activated by pressing **System, More, Show System**. Verify that there is an entry which reads, "UKB: Low Freq Extension".
2. Perform the Frequency Response Adjustment, located in the Adjustment Software.
3. Perform the following performance verification tests, located in the analyzer Calibration Guide:
 - Frequency Response
 - Displayed Average Noise Level
 - Residual Responses
4. If you have problems performing either of these tests, get in touch with the nearest Agilent Technologies sales and service office listed in the troubleshooting chapter of the analyzer User's Guide.